

BMA255 shuttle board

Bosch Sensortec

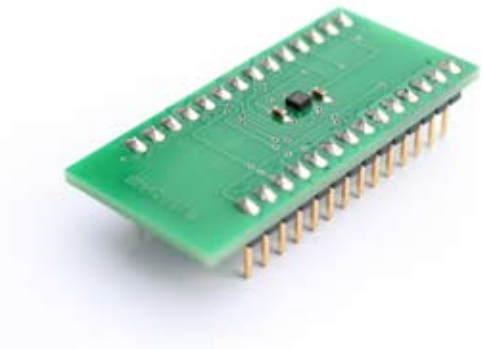

Description

The Bosch Sensortec BMA255 shuttle-board is a PCB with a BMA255 acceleration sensor mounted on it. It allows easy access to the sensors pins via a simple socket. As all Bosch Sensortec sensor shuttle boards have identical footprint, they can be plugged into Bosch Sensortec’s advanced development tools (e.g. the Development Board). Of course, the BMA255 shuttle board can also be used for customer’s own implementations.

Note: Product photo may differ from real product’s appearance

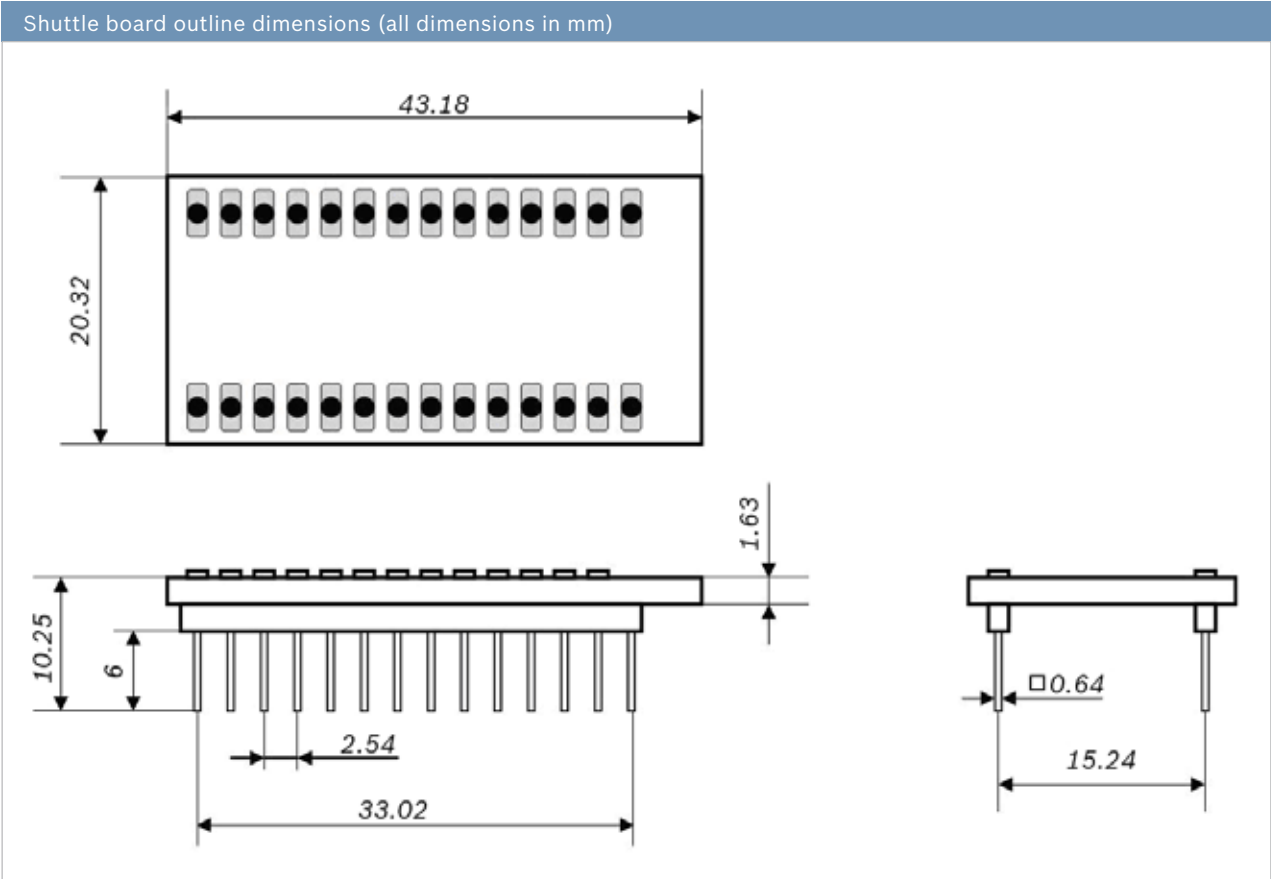

BMA255 shuttle board electrical layout

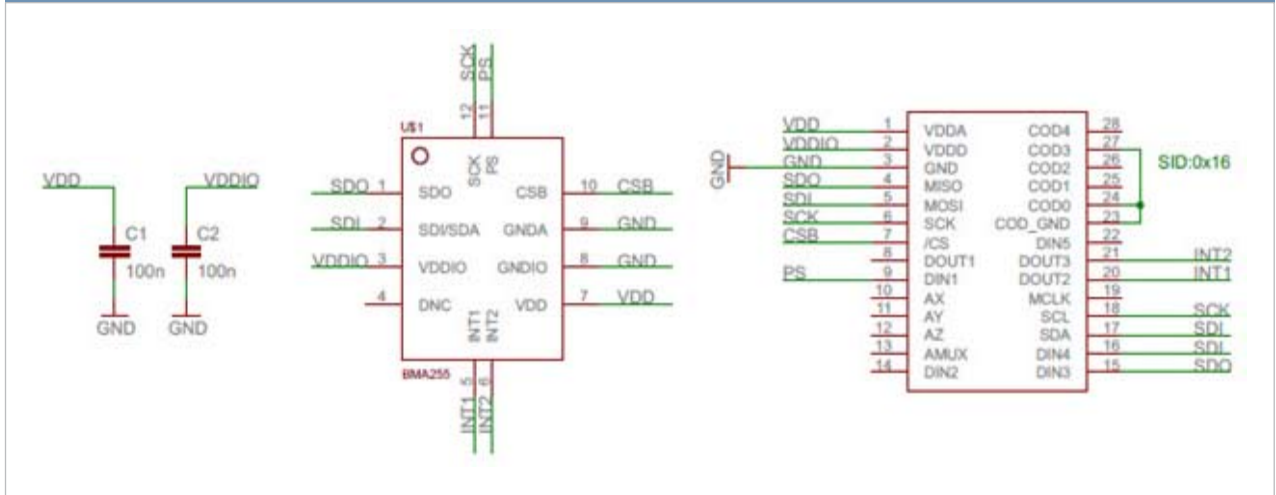

Deliverables

- ▶ BMA255 shuttle board

Headquarters

Bosch Sensortec GmbH

Gerhard-Kindler-Strasse 8
 72770 Reutlingen · Germany
 Telephone +49 7121 3535 900
 Fax +49 7121 3535 909
 contact@bosch-sensortec.com
www.bosch-sensortec.com